

# 1/4 THROUGH 3 TON CM SERIES 632 TROLLEY INSTALLATION INSTRUCTIONS

## ▲WARNING

IMPROPER INSTALLATION AND/OR OPERATION CAN RESULT IN THE TROLLEY COMING OFF OF BEAM.

### TO AVOID BODILY INJURY AND PROPERTY DAMAGE:

- DO INSTALL TROLLEY AS DIRECTED HEREIN.
- DO NOT OVERLOAD.
- DO NOT SIDE LOAD.
- DO MAKE CERTAIN END STOPS RESTRAIN TROLLEY.
- DO NOT LIFT PEOPLE OR LOADS OVER PEOPLE.

## GENERAL

Remove the Series 632 Trolley from the shipping carton and inspect the various parts for damage which may have been caused during shipping or handling. All Trolleys are shipped with two side frame/wheel assemblies, one load bar, two adjusting collars, two clevis pins and two cotter pins.

## ADJUSTMENT

Series 632 Trolleys can be adjusted for operation on a wide range of beam flange widths by using combinations of the holes in the adjusting collar and load bar. To determine the proper combination, measure the flange width of the beam on which the trolley is to be installed. Then using the chart, locate the nearest flange width and determine the load bar pin hole and the hole in the adjusting collar to be used. The letters in the chart refer to the holes in the side of the adjusting collar that are directly below the letters cast in the top flange.

**NOTE: The adjustment chart should only be used as a guide. Due to beam variations, a final collar adjustment may be necessary to obtain the required 1/8 to 3/16 inch wheel flange to beam flange clearance.**

## INSTALLATION

1. If the trolley is to be equipped with guards (optional item), they should be placed on the load bar prior to assembling the side frames to the load bar. Refer to Instruction Sheet provided with the guard kit.
2. Position trolley side #1 frame assembly on the load bar with "this side up" label on top. Insert the clevis pin through the proper hole of the adjusting collar and load bar as indicated in the figure below. Insert cotter pin

Through hole in tip of clevis pin and spread cotter pin to secure.

3. Place side #1 frame/load bar assembly on the beam and then slide the other side #2 frame assembly (with "this side up" label on top) onto the load bar. Position the remaining adjusting collar with the proper hole in the load bar and insert the remaining cotter pin through the hole in the tip of clevis pin and spread cotter pin to secure.
4. Due to variations in beam flange widths, measure to be sure that the distance between the trackwheel flanges is 1/8 to 3/16 inch (3 to 5 mm.) greater than the beam flange width. Adjust collars up or down if required. Adjusting collars must be set to the same letter or differ only by one letter in order to keep the hoist hook centered under the beam.
5. Check trolley for smooth operation on beam and for positive retention by trolley stops, if used.

## ▲WARNING

CM SERIES 632 TROLLEY MAY HAVE A DIFFERENT WHEEL PROFILE THAN THE TROLLEY BEING REPLACED.

### TO AVOID INJURY:

MAKE CERTAIN END STOPS RESTRAIN THE CM SERIES 632 TROLLEY. ADJUST OR REPLACE END STOPS, IF NECESSARY.

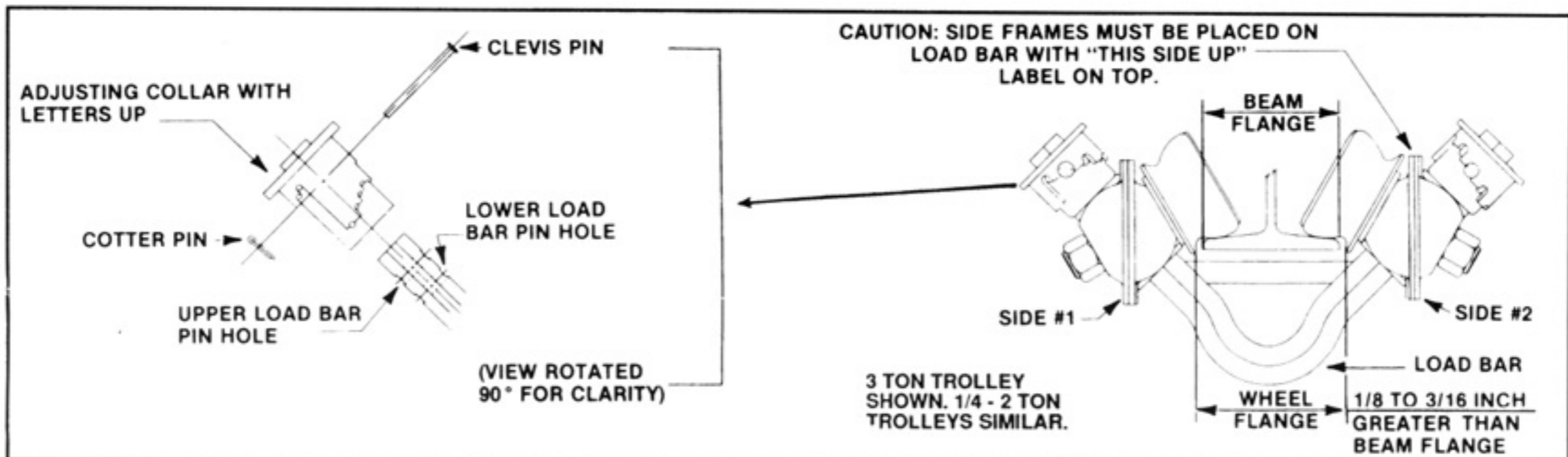

CAPACITY (TONS)	INCHES	2-1/2	2-21/32	2-23/32	2-15/16	3-1/16	3-7/32	3-11/32	3-1/2	3-5/8	3-29/32	4-3/32	4-7/32	4-11/32	4-1/2	4-5/8	4-25/32	4-15/16	5-1/32
	M.M.	64	67	69	75	78	82	85	89	92	99	104	107	110	114	117	121	125	128
		← USE LOWER BAR PIN HOLE →										← USE UPPER LOAD BAR PIN HOLE →							
1/4, 1/2 and 1	SIDE #1	A	A	B	B	C	C	D	D	E	A	A	B	B	C	C	D	D	E
	SIDE #2	A	B	B	C	C	D	D	E	E	A	B	B	C	C	D	D	E	E

**NOTE:** Beam flange widths larger than those listed in these charts require special load bar (contact CM).

1/2 and 2 ton trolleys are supplied, respectively, with loose 1/4 and 1-1/2 ton capacity labels for those applications where lower capacity trolleys must be used. For such applications, remove the capacity label from the trolley side frame and replace it with the capacity label packed loose with the trolley.

CAPACITY (TONS)	INCHES	3-1/2	3-19/32	3-3/4	3-7/8	4	4-1/8	4-9/32	4-13/32	4-9/16	4-13/16	4-15/16	5-3/32	5-7/32	5-13/32	5-17/32	5-11/16	5-13/16	5-15/16	
	M.M.	89	91	95	98	102	105	109	112	116	122	125	129	133	137	140	144	148	151	
		← USE LOWER BAR PIN HOLE →										← USE UPPER LOAD BAR PIN HOLE →								
1-1/2 and 2	SIDE #1	A	A	B	B	C	C	D	D	E	A	A	B	B	C	C	D	D	E	
	SIDE #2	A	B	B	C	C	D	D	E	E	A	B	B	C	C	D	D	E	E	

CAPACITY (TONS)	BEAM FLANGE WIDTHS																	
	INCHES	3-29/32	4-1/16	4-3/16	4-11/32	4-1/2	4-21/32	4-25/32	4-29/32	5-1/4	5-13/32	5-17/32	5-11/16	5-27/32	5-31/32	6-1/8	6-9/32	6-7/16
	M.M.	99	103	106	110	114	118	121	124	133	137	140	144	148	152	156	160	163
		← USE LOWER BAR PIN HOLE →								← USE UPPER LOAD BAR PIN HOLE →								
3	SIDE #1	A	B	B	C	C	D	D	E	A	A	B	B	C	C	D	D	E
	SIDE #2	B	B	C	C	D	D	E	E	A	B	B	C	C	D	D	E	E

**OPERATION**

1. Observe trolley load capacity. Do not overload.
2. Place load directly under trolley. Avoid off-center and side loading of any kind.
3. Read the instructions contained on this sheet as well as ANSI B30.11 and the manual provided with the hoist or other appliance used with this trolley.

**INSPECTION**

Periodic trolley inspection should be carried out coincident with hoist (or other appliance) inspection. As a minimum, a monthly visual inspection of the load bar and trackwheels should be carried out. The load bar should be replaced when the observed wear exceeds 15% of the original stock dimension. Wheels should be removed from service when there is any visual indication of fracture at transition of flange and tread sections.

**⚠ WARNING**

TROLLEY MAY FALL FROM BEAM IF IMPROPERLY OPERATED.

**TO AVOID INJURY:**

- DO NOT OVERLOAD
- DO NOT SIDE LOAD

**When ordering repair parts, specify the following:**

1. Trolley capacity.
2. Key number and part number of the part required.
3. Part name.
4. Quantity required.
5. Beam size.

**SERIES 632 TROLLEY PARTS LIST**

KEY NO.	PART NUMBER				PART NAME	NO. REQ'D
	1/4 & 1/2 Ton	1 Ton	1-1/2 & 2 Ton	3 Ton		
632-1	32123	32124	32125	32671	Load Bar	1
632-2	32603	32604	32605	32672	Side frame assembly	2
632-3	32655	32655	32656	32673	Trackwheel assembly	4
632-4	32657	32658	32659	32674	Trackwheel screw with washer and nut	4
632-5	32660	32661	32682	32682	Adjusting collar with clevis pin & cotter pin	2
632-6	3227	3228	3229	—	Guard with set screw (optional)	1
632-7	32664	32665	32667	32675	Label kit (all labels for trolley) - not shown	1

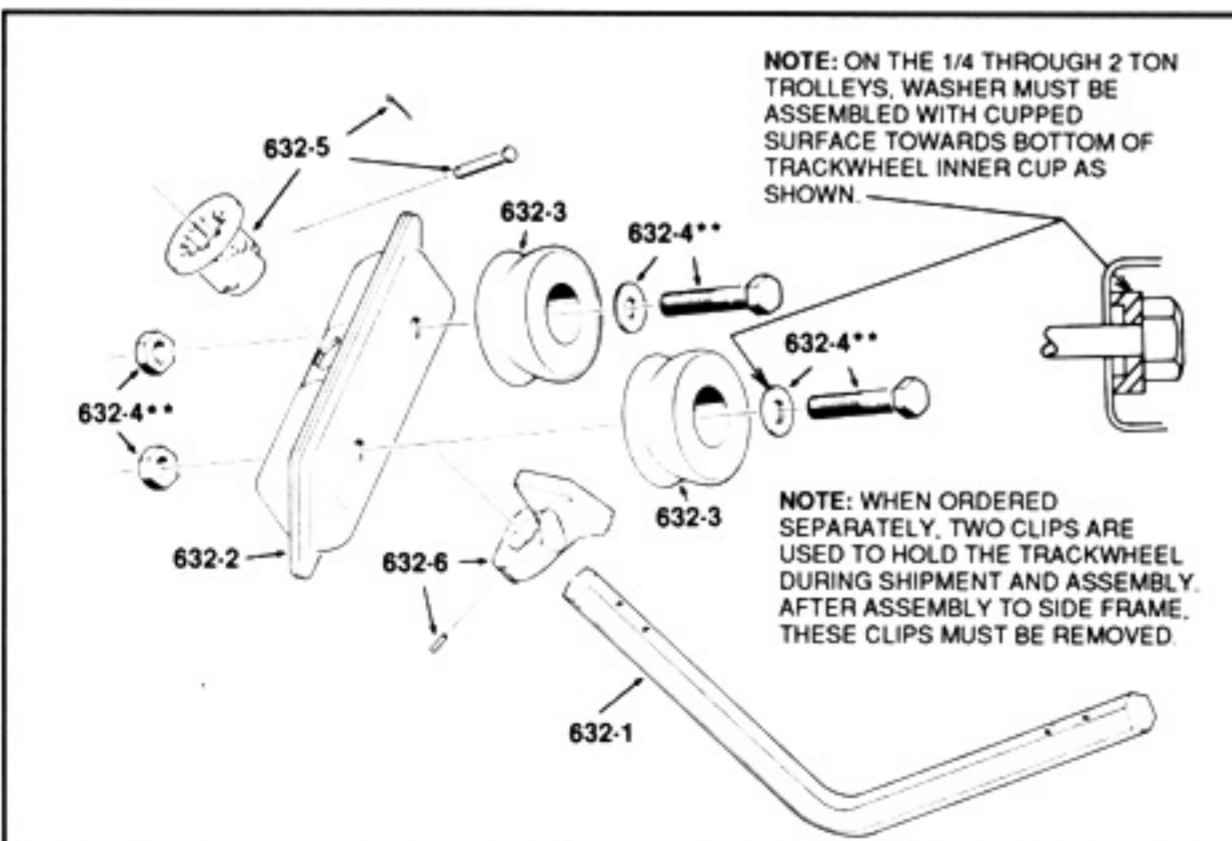

**\*\* IMPORTANT:** To avoid damage in use, threads on track wheel screw must not bear on side frame or track wheel, therefore, track wheel screw and nut must be assembled as shown with washer and head of screw inside track wheel.

**CM** COLUMBUS MCKINNON CORPORATION  
INDUSTRIAL PRODUCTS DIVISION  
140 JOHN JAMES AUDUBON PARKWAY  
AMHERST, NEW YORK 14228-1197  
716/689-5500 FAX: 716/689-5644